

Cl/SfB			
	(43)	Tn	

*Jaymart*

THE SARINA COLLECTION - RUBBER FLOORCOVERING

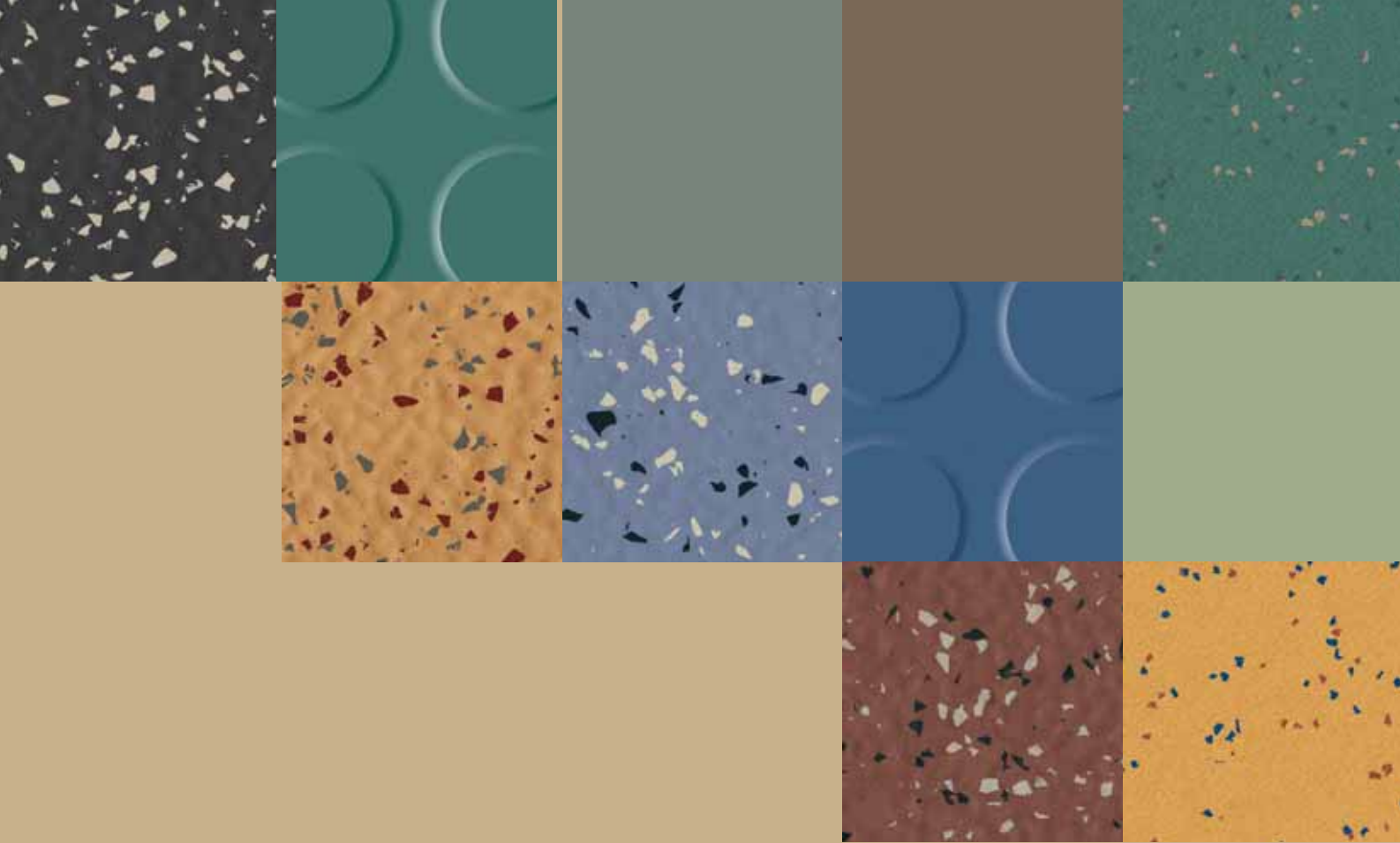

## PERFORMANCE

- BEAUTY -** Jaymart's Sarina range of rubber flooring comes in a wide variety of styles, textures, surfaces and colours
- ECONOMY -** The wear-resistance and resilience of our rubber floorings, combined with ease of installation, mean they are both low maintenance and highly economical
- COMFORT -** The Sarina range of rubber floorings provide a noticeably high level of walking comfort
- PEACE -** Measurably quieter than the vast majority of flooring types, Sarina rubber floorings improve the whole nature of an interior environment

## SAFETY

- FLAME-RETARDANT -** Improved safety as tested against internationally recognised standards
- BURN RESISTANT -** No more unsightly cigarette burns in the surface of the floor covering, no smouldering, and no harmful gas emissions
- ANTI-STATIC -** Minimised electrostatic generation and no perceptible static discharging
- CHEMICAL-RESISTANT -** Jaymart's Sarina rubber flooring remains undamaged by brief exposure to dilute acids or alkalis
- SLIP-RESISTANT -** Improved slip-resistance means fewer accidents



Jaymart

## Tough choice

For decades, rubber flooring has been one of the world's most popular hard-surface flooring types for a wide variety of indoor situations, such as airports, department stores, kindergartens, schools, hospitals, offices and residential buildings. Now, after many years of research, development and heavy testing, Jaymart brings you a new generation of Sarina rubber floorings.

Jaymart's Sarina is a range of innovative products that are tougher, more flexible and more suitable in more situations than ever before. These floorings are made of natural and synthetic rubber, using eco-friendly colour pigments and mineral fillers, yet every product in Jaymart's Sarina range is characterised by its increased load-bearing capacity and suitability for installation under the most varied and difficult conditions.

In heavy traffic situations, rubber flooring has for a long time been the obvious choice. It's safe, durable, flexible, low maintenance, and it's tough. Now, with the range and improved characteristics of Jaymart's Sarina rubber flooring, making a tough flooring choice has never been easier.

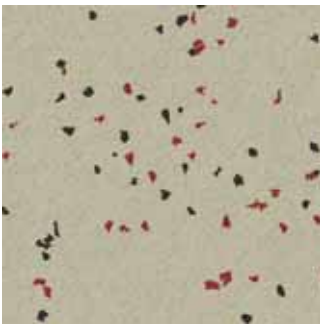

## Responsible choice

Jaymart's Sarina rubber flooring has been developed to improve performance and safety while also being more ecologically responsible. It has a lifetime cost that is well below most other flooring materials, and can also now be used in nearly any flooring application, including directly above under-floor heating.

The floorings are compatible with eco-friendly and solvent-free dispersion adhesives, they contain no PVC, formaldehyde, cadmium, asbestos, CFHC or plasticisers, and will not release any harmful substances in any situation.

FOR MORE INFORMATION ON ANY ASPECT OF SARINA RUBBER FLOORING,  
PLEASE CALL JAYMART ON 01373 864926

# SARINA BEAT V

Sarina Beat V is a heavy duty tile with non-directional colour chips inset into a hammerblow surface. The textured surface has been designed to limit the extent of light reflections.

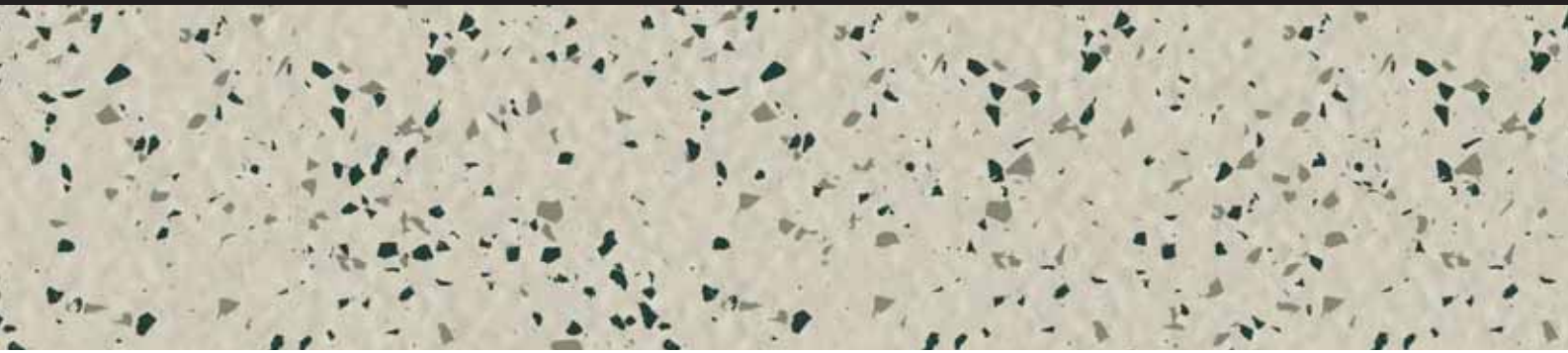

**STANDARD QUALITY  
SARINA BEAT V**

FOR ALL HEAVY CONTRACT APPLICATIONS

Sarina Beat V will accept dynamic pressure loads of up to 6 N/mm<sup>2</sup> and can therefore be used in areas that are subject to wheeled trolleys and forklifts.

3.5mm Thickness



**FFB 35**

TILE SIZE 1002mm x 1002mm

15 Standard Colours (all colours shown)

**FFB 36**

TILE SIZE 610mm x 610mm  
for raised access floors

4 Standard Colours  
212 213 411 711



**ELECTRICAL QUALITY  
SARINA BEAT V EL**

for electrostatically sensitive areas such as computer rooms, laboratories, science rooms, & operating theatres. Resistance to ground is 10<sup>6</sup> x 10<sup>8</sup> Ohm in accordance with ASTM F 150:1998.

3.5mm Thickness



**FFB 35 EL**

TILE SIZE 1002mm x 1002mm

5 Standard Colours  
212 213 411 711 713

**FFB 36 EL**

TILE SIZE 610mm x 610mm  
for raised access floors

4 Standard Colours  
212 213 411 711



A matching tread/nosing/riser section is also available. See page 18 for details.

● = price colour group

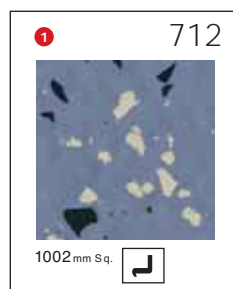
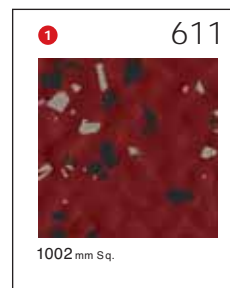
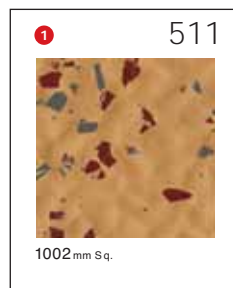
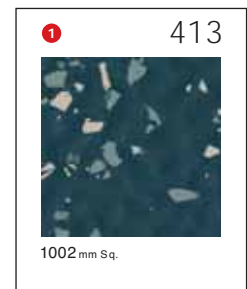
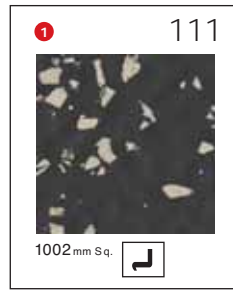

# SARINA BEAT UNI V

Sarina Beat Uni V is a single coloured synthetic rubber flooring tile with a hammerblow surface. The surface design structure has been developed to limit light reflection. Sarina Beat Uni V is suitable for most heavy contract floor installations.



SARINA BEAT UNI V  
 Hammerblow finish flooring tile.  
 2.7mm Thickness



FFB 35 UNI

TILE SIZE 503mm x 503mm

16 Standard Colours (all colours shown)

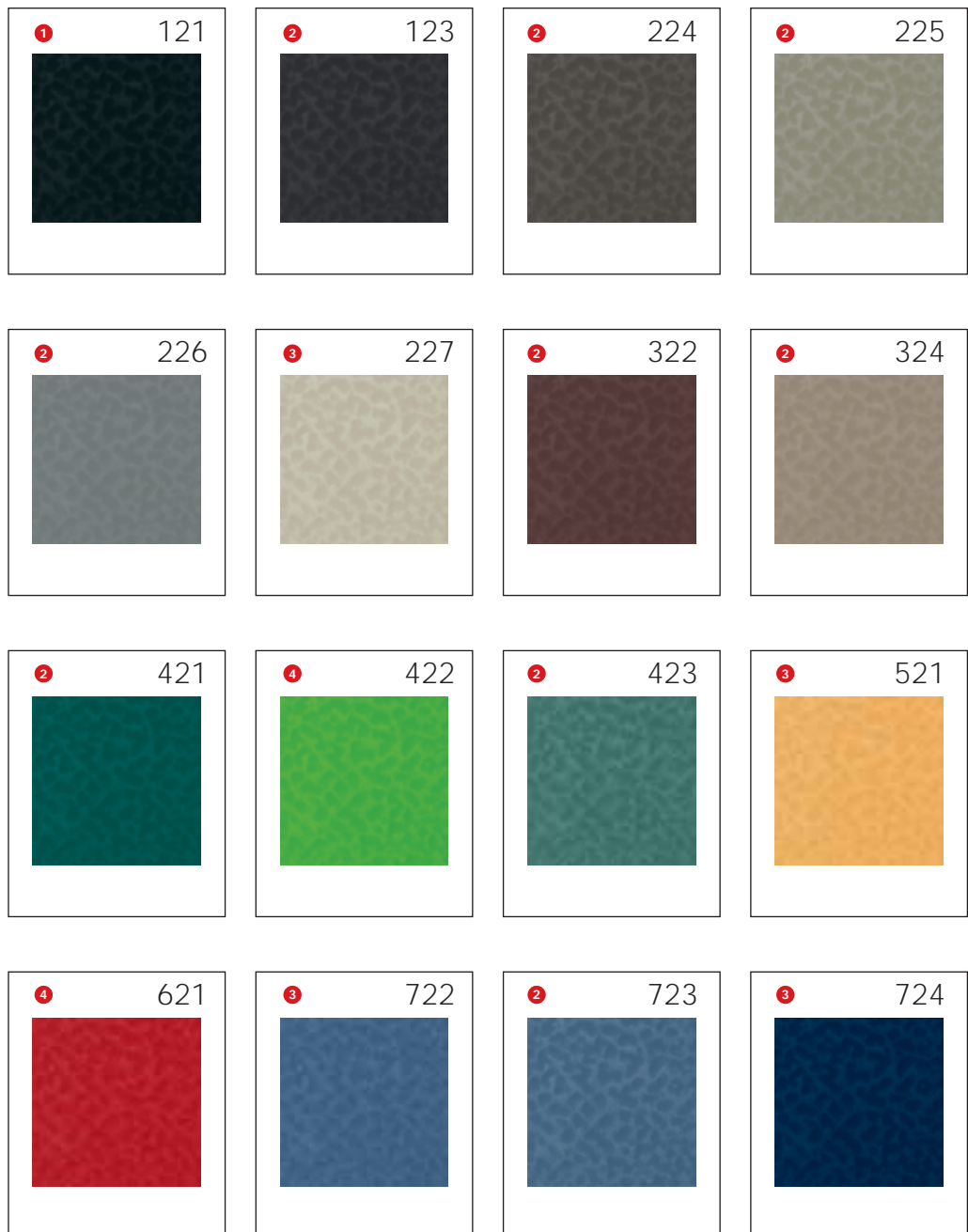

● = price colour group

# SARINA TOPLINE CARAT V

The Sarina Topline Carat V range of floorcoverings comprises a lightly textured non light reflecting surface with small non-directional chippings. Supplied in both roll and tile formats in a standard & two specialist qualities.





## SARINA TOPLINE CARAT V

Standard Quality for medium to heavy contract applications.

2mm Thickness



RFC 20

ROLLS 15.0m x 1.22m

FFC 20

TILES 610mm x 610mm

All Standard Colours (all colours shown)



## SARINA TOPLINE CARAT V EL

Special dissipative quality for electrostatically sensitive areas such as computer rooms, laboratories, science rooms, operating theatres etc. Resistance to ground is  $10^6$  x  $10^8$  Ohm in accordance with ASTM F 150:1998.

2mm Thickness



RFC 20 EL

ROLLS 15.0m x 1.22mm

FFC 20 EL

TILES 610mm x 610mm

5 Standard Colours



## SARINA TOPLINE CARAT V ELASTIC

Medium to heavy contract flooring with sound absorbing in-built underlay. Footfall sound reduction is 20dB.

4mm Thickness



RFC 40 TS

ROLLS 12.0m x 1.2mm

FFC 40 TS

TILES 610mm x 610mm

9 Standard Colours

● = price colour group

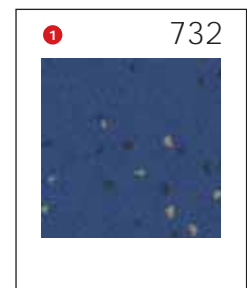
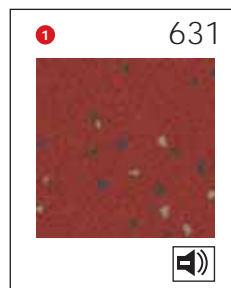
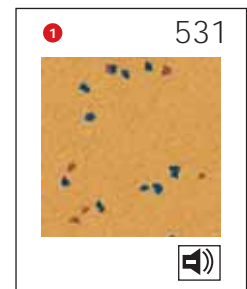
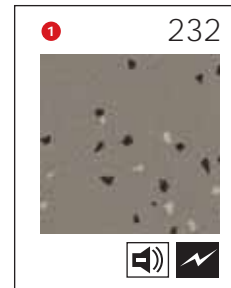

# SARINA TOPLINE UNI V

Smooth surface plain coloured synthetic rubber flooring for medium to heavy contract use.



# SARINA TOPLINE UNI V

2mm Thickness



RFT 20 Uni

ROLLS 12.0m x 1.22m

FFT 20 Uni

TILES 610mm x 610mm

18 Standard Colours (all colours shown)

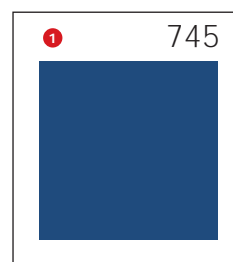
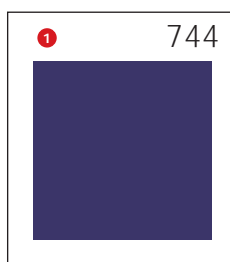
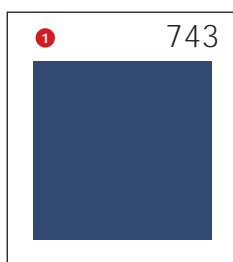
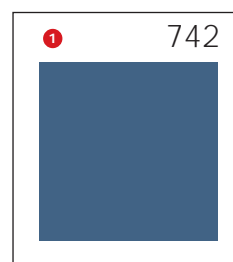
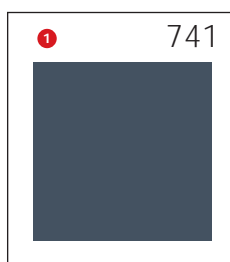
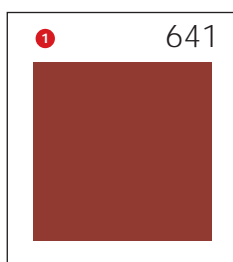
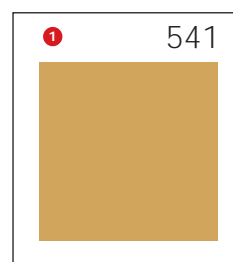
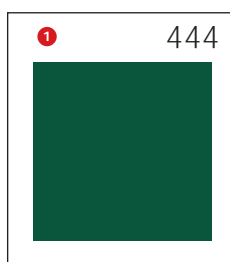
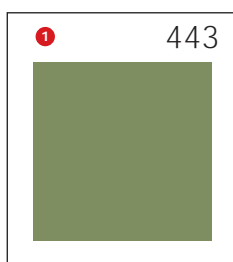
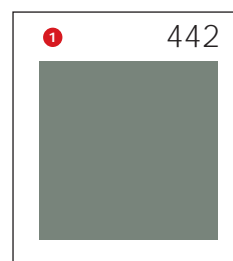
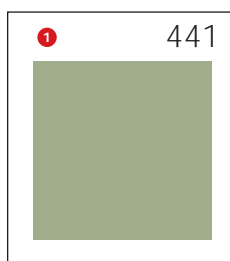
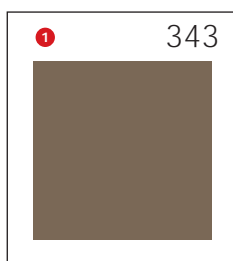
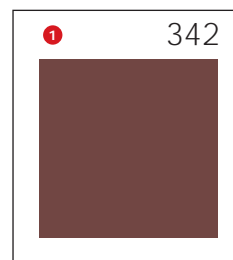
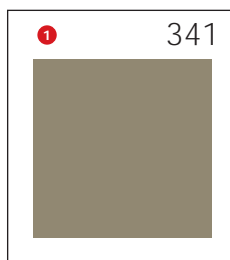
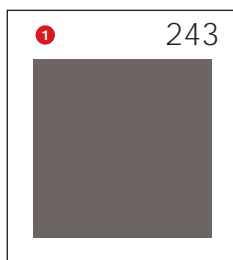
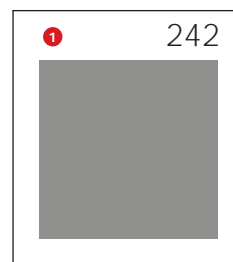
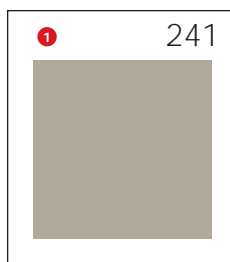
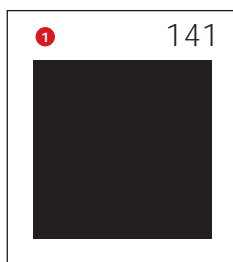

● = price colour group

# SARINA ZERO V

The Sarina Zero V range of synthetic rubber flooring tile is offered in the traditional and classic 30mm round stud design but the range of colours has been updated to take into consideration the current requirements of both new and refurbishment projects. Supplied in three thicknesses to meet even the highest demands on floorcoverings.



## SARINA ZERO V

### FB 415

4mm Gauge for extra heavy duty commercial applications such as airports, railway stations, public buildings, museums etc.

Will accept dynamic pressure loads of up to 6N/mm<sup>2</sup> and therefore can be used where fork lift trucks or heavy trolleys are in use.

A matching tread/nosing/riser section is also available. See page 18 for further details.

#### 4mm Thickness



TILE SIZE: 1002mm x 1002mm  
STUD SIZE: 30mm diameter x 0.5mm height  
18 Standard Colours (all colours shown)

### FB 325

For standard heavy contract use.

#### 3.2mm Thickness



TILE SIZE: 503mm x 503mm thickness  
STUD SIZE: 30mm diameter x 0.5mm height  
18 Standard Colours (all colours shown)

2.5mm

### FB 255

For medium contract/domestic applications.

#### 2.5mm Thickness



TILE SIZE: 503mm x 503mm  
STUD SIZE: 30mm diameter x 0.5mm height  
6 Standard Colours



### FB 415 OE

Oil and Grease Resistant Quality for heavy contract applications.

#### 4mm Thickness



TILE SIZE: 1004mm x 1004mm  
STUD SIZE: 30mm diameter x 0.5mm height  
3 Standard Colours



A matching tread/nosing/riser section is also available. See page 18 for details.

● = price colour group

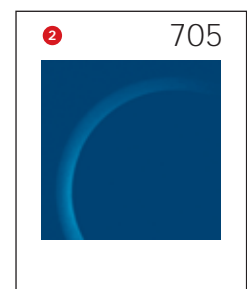
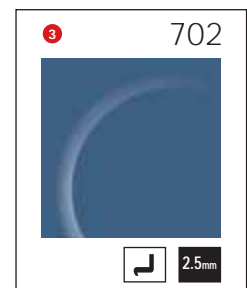
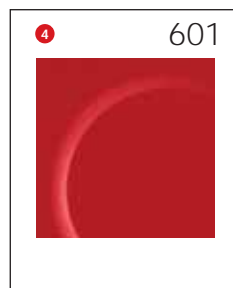
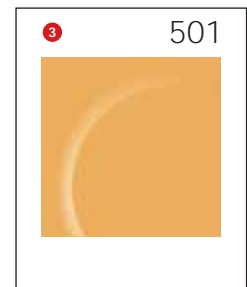
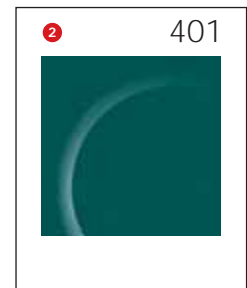
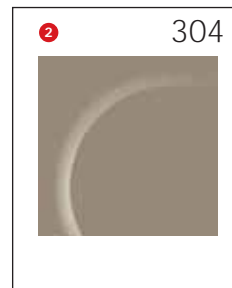
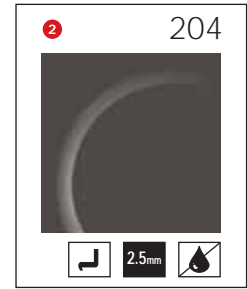
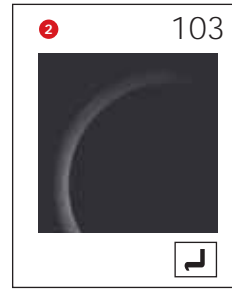

# SARINA SPIKE

Sarina Spike is a special floorcovering of non-directional colour chips inset into a hammerblow surface that has been developed for use in ice rink perimeters, golf and caddy rooms, barracks, veterinary clinics and other areas that require high performance impact resistant flooring.

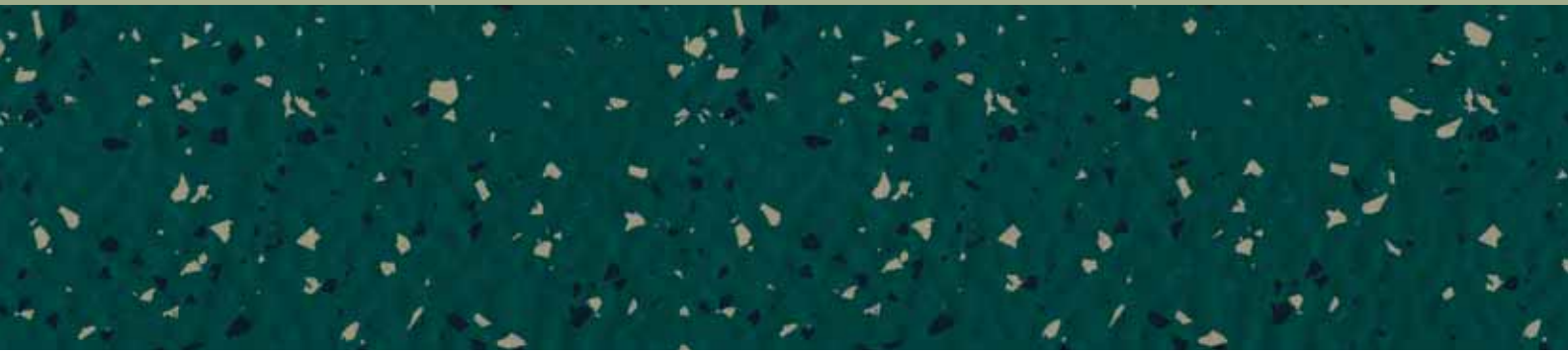

## SARINA SPIKE

### 976EH

Sarina Spike is resilient, extremely hardwearing and has high abrasion resistance and low wear characteristics. Sarina Spike is also suitable for use where dynamic pressure loads of up to  $6\text{N/mm}^2$  would be experienced e.g. vehicles and forklift trucks.

#### 9mm Thickness



TILE SIZE: 1002mm x 1002mm

4 Standard Colours



● = price colour group

# SARINA ACCESSORIES

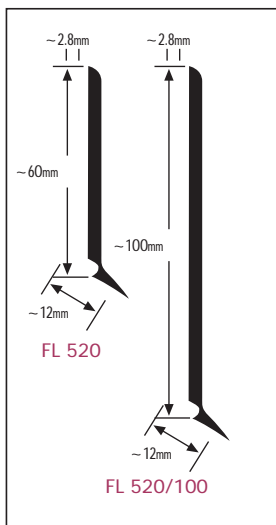
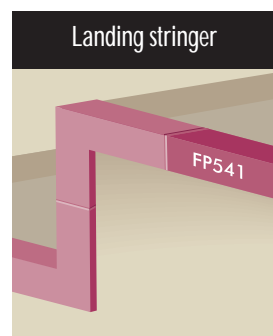

**FL 520**

Quantity:  
10m Roll

**FL 520/100**

Quantity:  
10m Roll

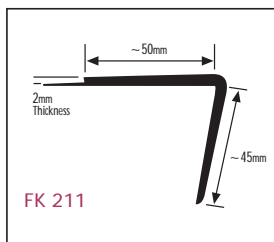

**FK 211**

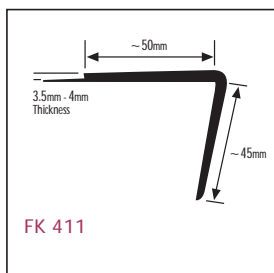

**FK 411**

**FK 211**

Flooring  
thickness:  
2mm

Quantity:  
Length  
of 2.5m

**FK 411**

Flooring  
thickness:  
3.5mm -  
4mm

Quantity:  
Length  
of 2.5m

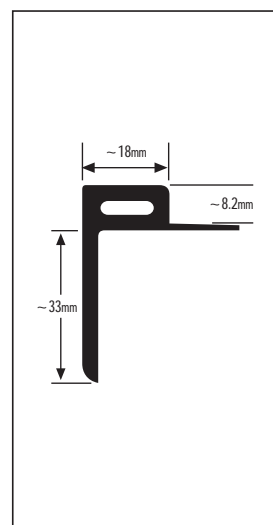

**FP 541**

Quantity:  
Length  
of 2.5m

	101	121	123	204	205	206	207	211	231	232	234	242	311	312	332	401	252
	121	123	204	225	226	227	211	231	232	234	242	311	312	332	421	403	
FK211	✓		✓		✓				✓						✓		
FK411	✓		✓		✓				✓						✓		
FK530	✓	✓	✓	✓	✓				✓	✓			✓		✓		✓
FK531	✓	✓	✓	✓	✓				✓	✓			✓		✓		✓
FK541	✓	✓	✓	✓	✓				✓	✓			✓		✓		✓
FL520	✓	✓	✓		✓	✓	✓	✓	✓	✓	✓	✓	✓			✓	✓
FL520/100	✓	✓	✓		✓	✓	✓	✓	✓		✓					✓	✓
Joint sealing compound	✓	✓	✓	✓	✓	✓	✓						✓	✓			



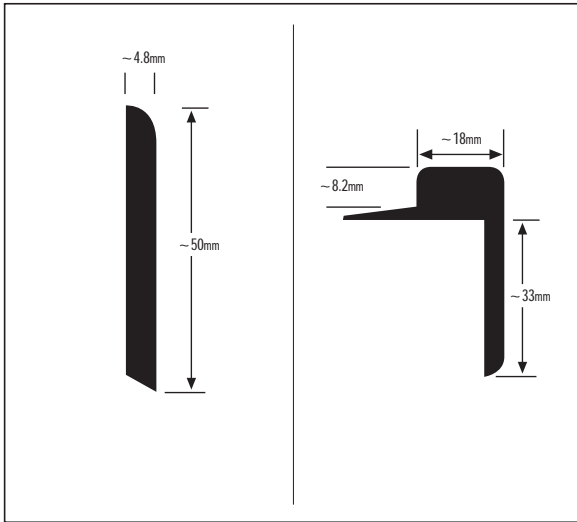
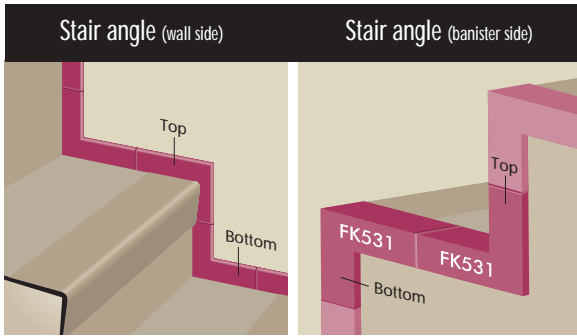

**FK 530 Top**  
**FK 530 Bottom**

Quantity:  
170mm x 170mm  
In pairs  
(1 Top plus & Bottom)

**FK 531 Top**  
**FK 531 Bottom**

Quantity:  
170mm x 170mm  
In pairs  
(1 Top plus & Bottom)

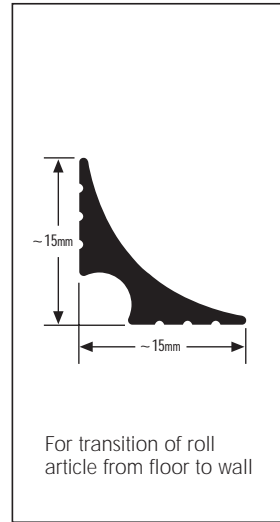

**HKP 1515**

Quantity:  
50m Roll

For transition of roll  
article from floor to wall

	411	412	413	511	601	701	702	703 723	704	705	711	712	713	731	733	734
FK211									✓	✓			✓			
FK411									✓	✓			✓			
FK530	✓					✓	✓	✓	✓	✓	✓	✓	✓			
FK531	✓					✓	✓	✓	✓	✓	✓	✓	✓			
FK541	✓					✓	✓	✓	✓	✓	✓	✓	✓			
FL520	✓				✓	✓		✓				✓	✓	✓	✓	✓
FL520/ 100						✓						✓	✓	✓	✓	✓
Joint sealing compound		✓	✓	✓		✓		✓			✓	✓	✓			

# SARINA STEPTREADS

## SARINA ZERO V

Combined tread/nosing/riser sections with round stud tread pattern.

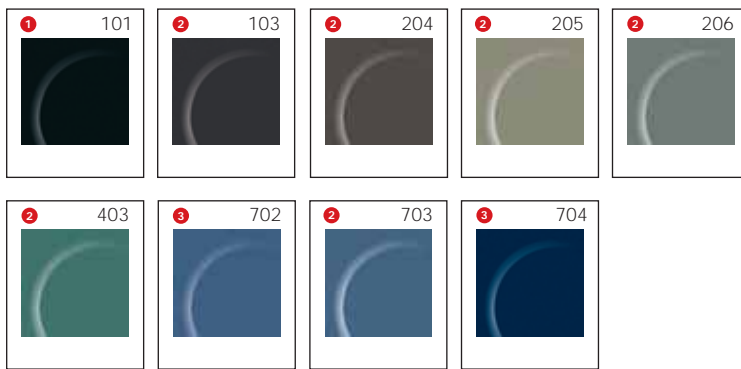
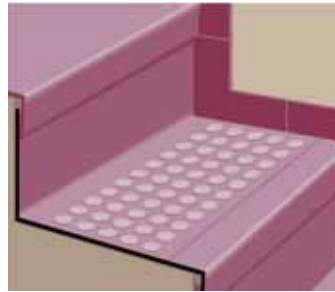

## FT 978

SECTION WIDTH: 1285 mm

## FT 979

SECTION WIDTH: 1614 mm

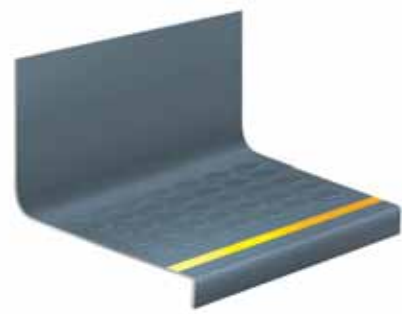
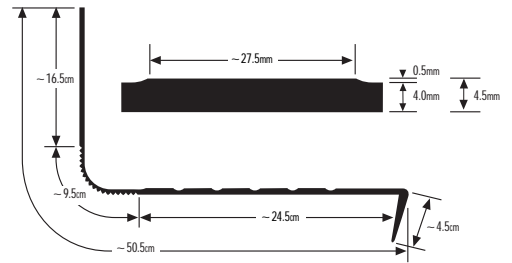

9 standard colours. All available with optional yellow safety inset in the nosing.

## SARINA BEAT V

Combined tread/nosing/riser sections with terrazzo hammerblow tread pattern.

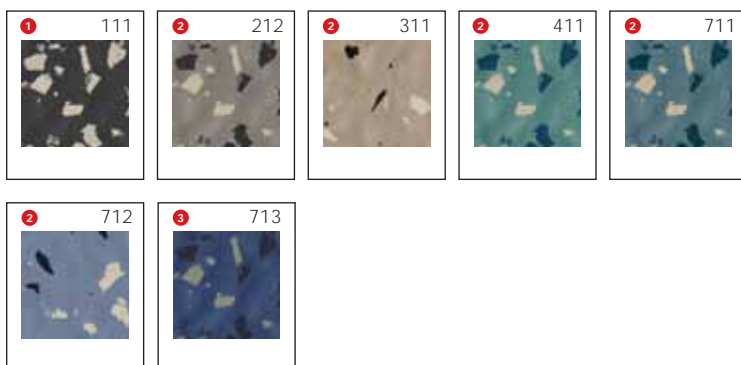
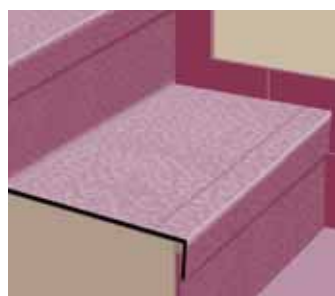

## FT 938

SECTION WIDTH: 1285 mm

## FT 939

SECTION WIDTH: 1614 mm

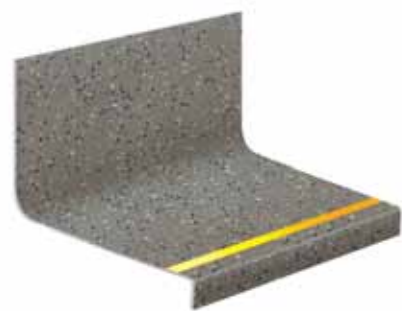
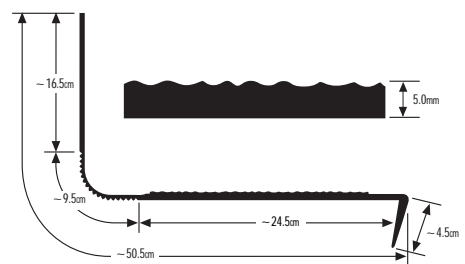

7 standard colours. All available with optional yellow safety inset in the nosing.

## CLEANING AND CARE

Regular cleaning and care of all rubber and vinyl floorings is important to retain the appearance and prolong the performance of the material.

Jaymart supply a range of floor dressings and cleaners to be used with the majority of their rubber and vinyl ranges.



### NOVA LONG-LIFE

Solids rich floor dressing, for application as soon as possible after installation of the floor-covering. Nova Long-Life creates a high shine but does not detract from the slip-resistant properties of the floor-coverings.

### NOVACARE

Floor maintainer, for daily and weekly cleaning.

### NOVA STARBRITE

Floor dressing remover.  
To remove Nova Long-Life prior to re-dressing.

Full cleaning and care guidelines are available for each product on application.

# SARINA TECHNICAL DATA

	STANDARDS	ZERO 4MM	ZERO 3.2MM	ZERO 2.5MM	BEAT	BEAT EL
HARDNESS	ISO 7619	85 Shore A	88 Shore A	85 Shore A	85 Shore A	81 Shore A
ABRASION RESISTANCE AT 5 N LOAD	ISO 4649	115mm <sup>3</sup>	140mm <sup>3</sup>	160mm <sup>3</sup>	115mm <sup>3</sup>	105mm <sup>3</sup>
RESIDUAL INDENTATION	EN 433	0.15mm	0.15mm	0.20mm	0.15mm	0.15mm
DIMENSIONAL STABILITY	EN 434	±0.3%	±0.3%	±0.3%	±0.3%	±0.3%
FIRE BEHAVIOUR	DIN 4102	B1	B1	B1	B1	B1
CIGARETTE-BURN RESISTANCE	EN1399	Surface shows no burns	Surface shows no burns	Surface shows no burns	Surface shows no burns	Surface shows no burns
ELECTRICAL PROPENSITY WHEN WALKED UPON	EN 1815	Antistatic < 2.0 kV	Antistatic < 2.0 kV	Antistatic < 2.0 kV	Antistatic < 2.0 kV	Antistatic < 1.0 kV
FOOTFALL SOUND ABSORPTION	ISO 140-8	12dB	9dB	6dB	10dB	10dB
THERMAL CONDUCTIVITY	DIN 52 612	0.39 W/mK	0.43 W/mK	0.39 W/mK	0.35 W/mK	0.40 W/mK
ANTI-SLIP PROPERTIES	DIN 51 130	R9	R9	R9	R9	R9
TEAR STRENGTH	ISO 34-1	38 N/mm	40 N/mm	40 N/mm	38 N/mm	40 N/mm
FLEXIBILITY	EN 435	No fissuring	No fissuring	No fissuring	No fissuring	No fissuring
COLOUR FASTNESS TO ISO 20 105-B02 ARTIFICIAL LIGHT		At least level 6 on the blue scale, grey scale level ≥ 3 acc. to EN 20 105-A02				
RESISTANCE TO EARTH	EN 1081	-----	-----	-----	-----	10 <sup>6</sup> x 9 x 10 <sup>7</sup> Ohm

BEAT UNI	TOPLINE UNI	TOPLINE CARAT	TOPLINE CARAT EL	TOPLINE CARAT ELASTIC	SPIKE
88 Shore A	92 Shore A	92 Shore A	92 Shore A	85 Shore A	72 Shore A
140mm <sup>3</sup>	200mm <sup>3</sup>	200mm <sup>3</sup>	180mm <sup>3</sup>	150mm <sup>3</sup>	90mm <sup>3</sup>
0.15mm	0.05mm	0.05mm	0.05mm	0.20mm	0.30mm
±0.3%	±0.3%	±0.3%	±0.3%	±0.3%	±0.3%
B1	B1	B1	B1	B1	B2
Surface shows no burns	Surface shows no burns	Surface shows no burns	Surface shows no burns	Surface shows no burns	Surface shows no burns
Antistatic < 2.0 kV	Antistatic < 2.0 kV	Antistatic < 2.0 kV	Antistatic < 1.0 kV	Antistatic < 2.0 kV	Antistatic < 2.0 kV
6dB	6dB	6dB	6dB	20dB	15db
0.43 W/mK	0.61 W/mK	0.61 W/mK	0.54 W/mk	0.12 W/mk	0.21 W/mk
R9	R9	R9	R9	R9	R9
40 N/mm	-----	-----	-----	-----	40 N/mm
No fissuring	No fissuring	No fissuring	No fissuring	No fissuring	No fissuring
					→
-----	-----	-----	10 <sup>6</sup> x 9 x 10 <sup>7</sup> Ohm	-----	

# TERMS & CONDITIONS

All quotations and contracts are subject to the following conditions unless otherwise stated subsequently by us in writing, and no qualification of these conditions in the customer order or acceptance shall be deemed to form part of this contract.

1. **Delivery:** Any items as to rate or time of DELIVERY are not to be deemed to be the essence of the contract and no guarantee can be given or implied thereto. We, however, will make every reasonable effort to ensure delivery in accordance with requirements so far as circumstances permit.
2. All orders are subject to our final acceptance at Westbury and thus the contract of sale is explicitly agreed to have been made at Westbury, Wiltshire. English Law shall apply and any dispute shall be settled in the English Courts.
3. ALL PRICES are quoted without engagement and, unless otherwise expressly stated by us in writing, subject to alteration without notice.
4. **DESPATCH OF ORDERS:** All goods are sent by the most convenient method available to us at the time of despatch unless otherwise specified. ANY GOODS FOR DELIVERY TO ADDRESSES OTHER THAN THOSE OF THE PURCHASER are only sent at the PURCHASER'S RISK.
5. **CARRIAGE:** Please see our current price list for carriage terms
6. **DELIVERY TO SITE:** THE PURCHASER WILL BE RESPONSIBLE FOR OFF-LOADING the goods and in accordance with normal transport practices such goods will be delivered to the goods inwards department or reception on the ground floor.
7. **SELECTION OF GOODS:** Is a matter solely for the purchaser, who should ascertain in advance of ordering, the suitability and colour, etc. of goods for the purpose required. Technical details and samples are available on request.
8. **TECHNICAL DESCRIPTION AND DATA.** Such descriptions whilst given as a guide in good faith are subject to alteration by the seller without notice. In particular all dimensions are approximate only.
9. **LIABILITY:** We will not be liable for any indirect or consequential loss whatsoever arising from, or in conjunction with, the supply of defective goods, delay in delivery, non-delivery, loss or damage to goods in transit or to the property of the purchaser, or any third person howsoever caused. If goods have been exported, customers are welcome to return the goods to our premises in Westbury where a decision can be made regarding any action to be taken.
10. **CLAIMS:** No claim for ANY DEFECT in goods supplied will be accepted unless made in WRITING within 3 days from the date of delivery. Goods returned to us within 10 days from receipt in exactly the same condition in which they were received, will be credited only if we also judge them to be defective, but will not form the subject of any claim for labour cost or other loss of any kind. No claim for loss or damage in transit will be accepted unless signed for as such and confirmed in writing and verbally within 10 days from the date of despatch. A clear signature to the carriers for goods concerned will indicate to the carriers and to us that they were received in perfect condition.
11. **DEFECTIVE GOODS:** Under no circumstances whatsoever will we accept return of goods for credit when they have already been installed, used or laid. Defects should be observed on receipt, i.e. prior to installation, use or laying, and be notified to us immediately, both verbally and in writing, so that we can decide what action may be taken. In the case of goods to be exported, inspection should be made prior to shipment.
12. **COLOURED GOODS:** JAYMART floorings and accessories are produced by highly sophisticated and modern manufacturing methods. However, due to differing production batches and or varying individual product manufacturing processes, colour and shading variations can occur and must be accepted.
13. **COLOUR SAMPLES:** The small hand feeler samples given or sent to enquirers are an indication of colour only . They are not necessarily representative of the actual product colour shade to be supplied
14. **PRODUCT CHANGES:** The policy of the Company is one of increasing improvement and development, so we reserve the right to add or delete from the range or to change products without notice
15. **TITLE TO GOODS:** We reserve the right to retain, if we should so decide, the title to goods supplied under these terms of sale until the purchaser has discharged all sums owing to us. Until such discharge, the purchaser shall hold the goods, whether or not sold to another party upon trust for ourselves and grant us the right, if we so wish, to enter the purchaser's or its agent's premises to recover any such goods.
16. **CANCELLATIONS.** We will consider, but not be bound to accept, any request for cancellation of an order, and acceptance shall be on such terms as may be agreed by us in writing.
17. **RETURNS:** We do not normally accept return of perfect goods if correctly supplied as ordered. We therefore strongly recommend that customers check quantity, colour and product requirements carefully before ordering. If goods are accepted for return for whatever reason, we reserve the right to levy an administration charge together with carriage costs incurred for original despatch. No requests for return will be considered more than 3 months after invoice date.
18. **COLLECTIONS:** Our warehouse is usually open for collection from Monday to Friday (9 a.m. to 12.30 p.m. and 2 p.m. to 5.30 p.m.) excluding holidays. We kindly request customers, however, to give us reasonable advance warning of intended collection of goods required. We regret that we cannot accept any claims whatsoever in such cases, if goods are unavailable at the time of collection. All promises of stock availability are given in good faith, but should not be regarded as guaranteed correct.
19. **SETTLEMENT:** Approved credit account customers should make their payments by the end of the month following the date of invoice. Cleared funds are required from non-credit account customers before goods can be released. Prepayment may be made by cheque, postal order, cash, bank transfer/CHAPS or most major credit/debit cards.
20. **VAT:** Is chargeable extra at current rate on prices listed.

*Jaymart*

FOR FLAWLESS FLOORING  
& MATS THAT MATTER

# Jaymart



Aluminium entrance matting systems



Rubber and vinyl floor coverings



Multi purpose mats and matting



Anti-fatigue and duckboard matting



Natural carpeting and domestic mats



Entrance/foyer matting

FOR FURTHER INFORMATION, FREE COPIES OF ANY OF OUR OTHER BROCHURES  
OR FREE SAMPLES PLEASE PHONE:

01373 864926

[www.jaymart.co.uk](http://www.jaymart.co.uk)

email: [matting@jaymart.co.uk](mailto:matting@jaymart.co.uk)

Jaymart Rubber & Plastics Ltd., Woodlands Trading Estate, Eden Vale Road, Westbury, Wiltshire BA13 3QS Fax: 01373 858454



Issue SMB 001